

# Houston Ball 2019

## 1 THE HOLLIN BUSS J32 · 2/4L

RSCDS XXIV 8 · Crib: MiniCribs · Diagram: Keith Rose's Diagrams

- 1-8 1s+2s Adv+Ret, cross RH & dance RH across 1/2 way
- 9-16 2s+1s Adv+Ret, cross LH & dance LH across 1/2 way
- 17-24 1s dance slip step down for 4 & back to top
- 25-32 1s set, cast 1 place & 2s+1s turn RH

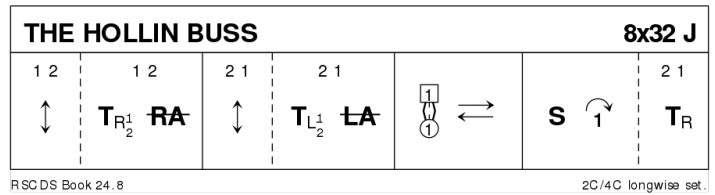

## 2 DUKE OF PERTH R32 · 3/4L

RSCDS I 8 · Crib: MiniCribs · Diagram: Keith Rose's Diagrams

- 1-8 1s turn RH, cast to 2nd place, turn LH to face 1st corners
- 9-16 1s turn 1st corner, partner, 2nd corner, & partner to face 1st corners
- 17-24 1s set to & turn 1st corner 2H, set to & turn 2nd corner
- 25-32 1s dance Reel of 3 on opposite sides giving LSh to 1st corner & cross back to own sides

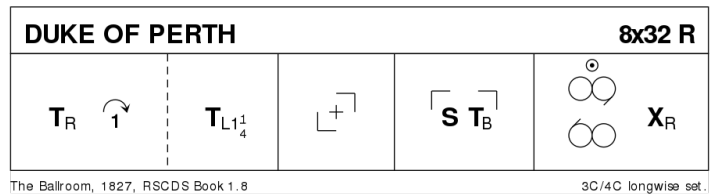

## 3 O'ER THE MOUNTAINS S32 · 3/4L

Paula Carnes 2017

- 1-8 1s turn BH, dance mirror reel of 3 on own sides. In & down to start
- 9-16 1s 4 bar cast to 2nd place, 2s up on 3&4; 1/2 figure of 8 LSh around 1st corner. End on 2nd corner diagonal, LH with partner & RH with 2nd corners
- 17-24 Strathspey balance and turn with 2nd corners;  
Turn 2nd corner RH, turn partner LH 3/4 ending on 1st corner diagonal
- 25-32 Repeat bars 17-24, ending 2nd place own sides.

## 4 BRATACH BANA R32 · 3/4L

John Drewry: *Bon Accord Book of Scottish Country Dances* · Crib: *MiniCrib*s · Diagram: *Keith Rose's Diagrams*

- 1-8** 1s turn RH & cast 1 place, 1s dance LSh round 1st corners to 2nd place opposite side facing 2nd corners
- 9-16** 1s dance 1/2 Reel of 3 on the sides & dance 1/2 Reel of 3 across (1M with 3s at top, 1L with the 2s)
- 17-24** 1s turn LH, turn 3rd crnr RH (1st crnr person) & pass RSh to turn 4th crnr RH ending in 2nd pl own side in prom hold with 4th crnr
- 25-32** 1s+4th crnr Prom diag across (pass RSh) to diag opp crnr & 1/2 turn to end 1s in 2nd pl opp side, 1s dance 1/2 Diag R&L (M up, L dn) to end in 2nd pl

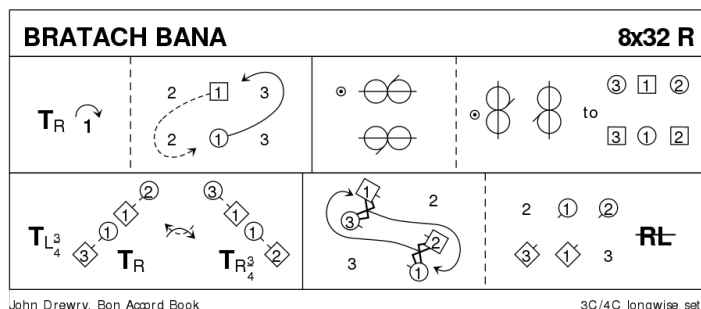

## 5 INDIAN RIVER STRATHSPEY S32 · 3T

George Senyk: *Scottish Country Dances in Diagrams. Ed. 9* · Crib: *MiniCrib*s · Diagram: *Keith Rose's Diagrams*

- 1-8** 1s+2s+3s in prom hold dance a reel of 3 across the set, 1s passing 3s RSh to start
- 9-16** 1s (with Lady leading) dance RH across with 3s & dance LH across with 2s
- 17-24** 2s+3s dance Ladies Chain across the set **while** 1s set (2 bars) & then dance between 2s+3s & cast individually back to places
- 25-32** 1s+3s dance 1/2 R&L, 1s+2s dance 1/2 R&L to end 3 1 2

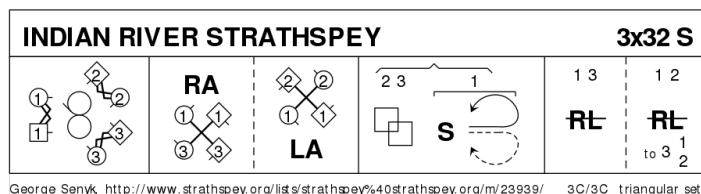

## 6 TRIP TO TIMBER RIDGE R32 · 3/4L

Linda Henderson: *RSCDS LII 12* · Crib: *MiniCrib*s · Diagram: *Keith Rose's Diagrams*

- 1-8** 1s turn RH, cast (2s step up) then 1L+2s & 1M+3s dance RH across. 1s end facing 1st corners
- 9-16** 1s dance Corner Pass+Turn with 1st corners, pass RSh & repeat with 2nd corners. 1s pull back RSh to end BtoB in centre facing opp sides
- 17-24** 2s+1s+3s dance Double Triangles. Bars 23-24 1s petronella turn to 2nd place own sides
- 25-32** 2s+1s+3s circle 6H round and back

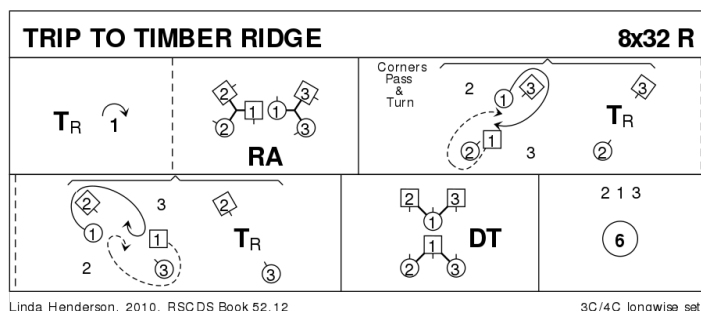

## 7 INTERMISSION

## 8 THE BLACK MOUNTAIN REEL R32 · 5/5L

Derek Haynes: Carnforth Collection of SC Dances 3 · Crib: MiniCrib · Diagram: Keith Rose's Diagrams

- 1-8** 1s & 3s cross RH & cast down 1 place, dance 1/2 Fig of 8 round the couples above them & cross to face 1st corners
- 9-16** 1s & 3s turn 1st corners RH & partner LH, turn 2nd corner RH & partner LH to face 1st corners again
- 17-24** 1s & 3s dance diagonal reels of 4 with 1st corners
- 25-32** All dance RH across once round (1L with 2s, 1M+3L with 4s & 3M with 5s), 1s & 3s turn ptrns LH & cast one place

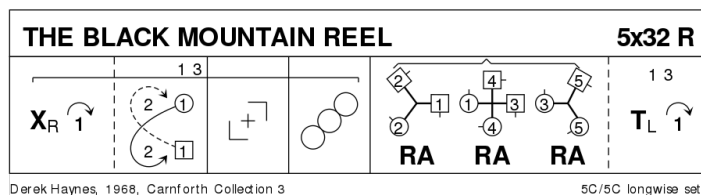

## 9 THE MINISTER ON THE LOCH S32 · 3/3L

Roy Goldring: Magazine Dances 2005-2009 · Crib: MiniCrib · Diagram: Keith Rose's Diagrams

- 1-8** 1s+2s dance Diamond Poussette
- 9-16** 1s dance down for 2 steps, turn 2H, dance up to top & turn 2H
- 17-24** 1s+3s dance double Fig of 8 round 2s with 1s casting to start
- 25-32** 1M+2M turn LH 1.1/2 times **while** 1L+2L turn RH 1.1/2 times, 1M+3M turn RH 1.1/2 times **while** 1L+3L turn LH 1.1/2 times

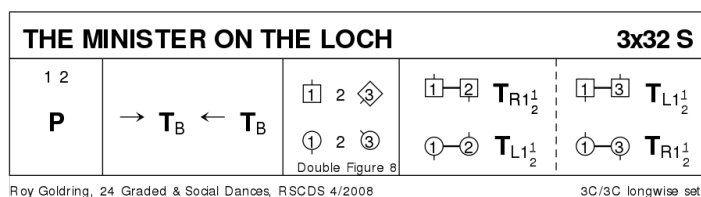

## 10 THE MACHINE WITHOUT HORSES J32 · 3/4L

David Rutherford: RSCDS XII 12 · Crib: MiniCrib · Diagram: Keith Rose's Diagrams

- 1-8** 1s set, cast & dance RH across with 3s
- 9-16** 1s set, cast up & dance LH across with 2s
- 17-24** 1s followed by 2s dance down, cast up behind 3s, in & dance up to top & 1s cast back to 2nd place
- 25-32** 2s+1s dance R&L

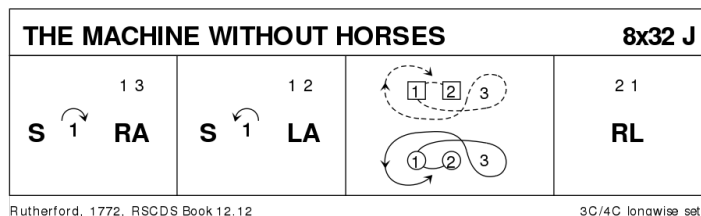

## 11 FLOWERS OF EDINBURGH R32 · 3/4L

RSCDS I 6 · Crib: MiniCrib · Diagram: Keith Rose's Diagrams

- 1-8** 1L followed by partner casts below 3s, 1L crosses & dances up behind Men as 1M dances up centre to 1st places on opposite side & 1s set
- 9-16** 1M followed by partner repeat above Fig & set in own places
- 17-24** 1s lead down the middle & back
- 25-32** 1s+2s dance Poussette. 2 1 3

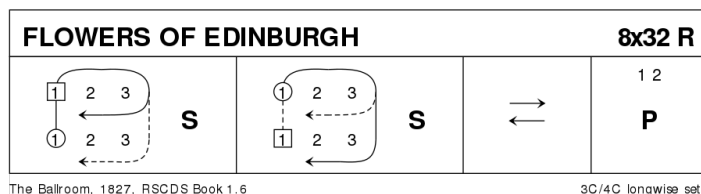

## 12 GYPSY WEAVER S32 · 3/4L

Denise Peet: *Between the Rivers* · Crib: *MiniCribs* · Diagram: *Keith Rose's Diagrams*

- 1-8** 1s+3s dance RSh 3/4 round partner to end in line of four in middle (Ladies face down, Men up), 1/2 reel of 4, 1s+3s RSh 3/4 round prtnr to own sides
- 9-16** 2s+1s Set+Link, 3s+1s Set+Link
- 17-24** 1s+3s+2s 1/2 RSh reel of 3 on own sides, 1L followed by partner casts up 1 pl crossing to opp sides & turning left turns prtnr LH to face 1st crnrs
- 25-32** 1s Pass+Turn with 1st corners & pass RSh to face 2nd corners, Pass+Turn with 2nd corners, 1s ending 2nd place own sides

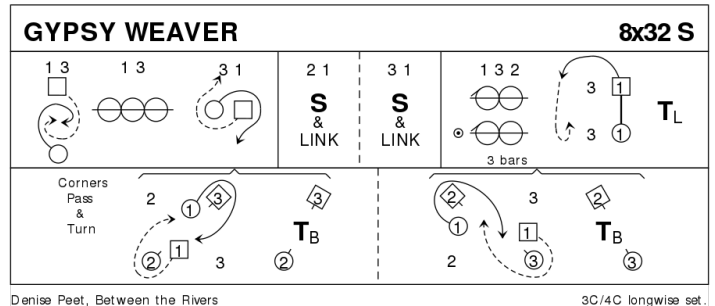

## 13 THE ROTHESAY RANT J32 · 4S

Anna Campbell Holden: *Collins Pocket Reference: Scottish Country Dancing* · Crib: *MiniCribs* · Diagram: *Keith Rose's Diagrams*

- 1-8** All 1/2 turn partners RH, retain hold & give LH to next person & all set (M facing out), 1/2 turn next person LH & all set end Ladies turning inwards
- 9-16** 1s+3s (in 2nd & 4th places) dance 1/2 Ladies' Chain & 1/2 R&L
- 17-24** 2s+4s dance 1/2 Ladies' Chain & 1/2 R&L
- 25-32** All circle 8H round & back

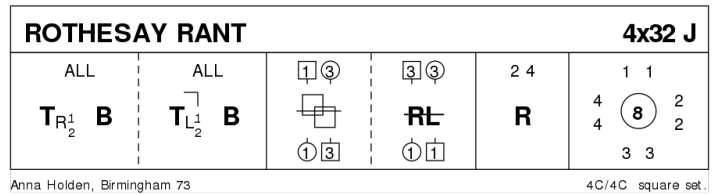

## 14 INTERMISSION

## 15 PELORUS JACK J32 · 3/4L

Barry Skelton: *RSCDS XLI 1* · Crib: *MiniCribs* · Diagram: *Keith Rose's Diagrams*

- 1-8** 1s cross RH & cast 1 place, dance RH across with 3s. 1s end with Man facing his 1st corner with his partner behind him
- 9-16** 1s dance Alternating Tandem 1/2 reel of 3 with 1st corners to face Man's 2nd corner, 1s dance Alternating Tandem 1/2 reel of 3 with 2nd corners
- 17-24** 1s dance Alternating Tandem 1/2 reels of 3 with Ladies' 1st corner (pstrn), 1s dance Alternating Tandem 1/2 reel with Ladies' 2nd corner (pstrn)
- 25-32** 1M followed by partner dance into LH across with 2s, 1s retain LH & 1/2 turn to own sides & 2s+1s+3s set

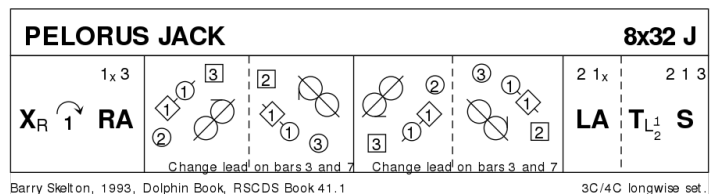

## 16 THE ROSE GARDEN S24 · 2/4L

Kathy Wendell: San Francisco Collection Volume 2 · Crib: MiniCrib · Diagram: Keith Rose's Diagrams

- 1-8** 2s followed by 1s lead down middle for 2 bars, 1s followed by 2s lead up to top, 1s cast to 2nd pl **while** 2s loop round to 1st pl & 2s+1s cross RH
- 9-12** 2s+1s set advancing into middle passing partners LSh & turn right about to face partner, turn partners 2H back to own sides
- 13-16** 2s facing 1s set advancing (up down) passing LSh & turn right about to face other person & turn 2H back to original places
- 17-24** 1s+2 dance 4H round to left & dance 1/2 Diamond Poussette

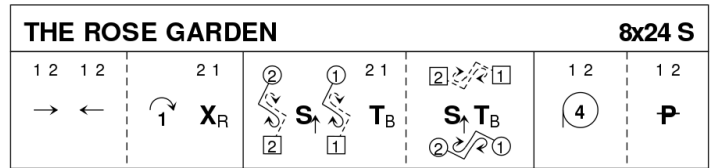

Kathy Wendell, 1993, San Francisco 2

2C/4C longwise set.

## 17 JOIE DE VIVRE J32 · 3/4L

Irene van Maarseveen: RSCDS XXXIX 2 · Crib: MiniCrib · Diagram: Keith Rose's Diagrams

- 1-8** 1s set, cast 1 place, 1s dance down between 3s & cast back to 2nd place on own sides
- 9-16** 2s+1s+3s turn RH & chase 1/2 way round clockwise
- 17-24** 3s+1s+2s dance DoSiDo, set & 1/2 turn partners RH for Allemande
- 25-32** 3s+1s+2s dance Allemande

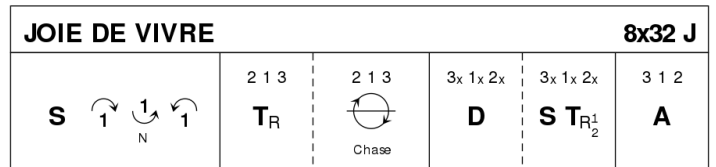

Irene van Maarseveen, 1996, RSCDS Book 39.2

3C/4C longwise set.

## 18 WEST'S HORNPIPE R32 · 4/4L

Five Traditional Scottish Country Dances for 1965 · Crib: MiniCrib · Diagram: Keith Rose's Diagrams

- 1-8** 1s cross down & dance reflection reels of 3 on opposite sides
- 9-16** 1s cross down to dance reflection reels of 3 on own sides
- 17-24** 1s lead down the middle & back to top (1s end facing 2s diagonally)
- 25-32** 1s set to 2s & dance down to 4th place (2s+3s+4s step up 27-28), 4s+1s circle 4H round to left

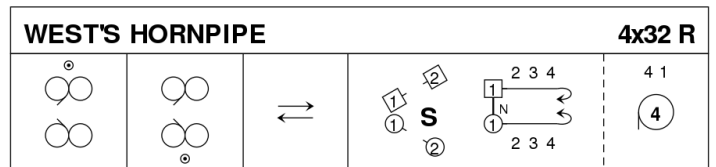

Ladies Pocket Book, 1797, RSCDS 5/1965

4C/4C longwise set.

## 19 STRATHGLASS HOUSE S32 · 3/4L

Robert Bremner: RSCDS XIII 9 · Crib: MiniCrib · Diagram: Keith Rose's Diagrams

- 1-8** 1s+2s+3s set & circle 6H round 1/2 way, set & continue to circle 6H round back to place
- 9-16** 1s Lead down below 2s, cross & cast down round 3s, lead up between to top & cast 1 place (on opposite sides) to face 1st corners
- 17-24** Turn 1st corner RH, partner LH, 2nd corner RH & partner LH to end in 2nd place opposite sides
- 25-32** 2s+1s+3s Adv+Ret for 2 steps & 1s turn 2H 1.1/2 times to own sides

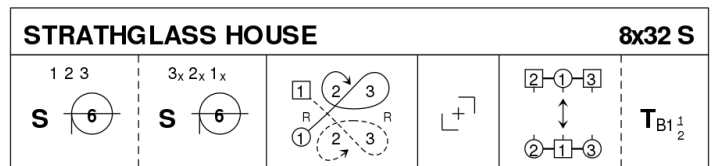

Robert Bremner, 1757, RSCDS Book 13.9

3C/4C longwise set.

## 20 MAIRI'S WEDDING R40 · 3/4L

James B Cosh: *Twenty Two SCD · Crib: MiniCribs · Diagram: Keith Rose's Diagrams*

- 1-8** 1s turn RH & cast to 2nd place, 1s turn LH to face 1st corners
- 9-16** 1s dance 1/2 diagonal reel of 4 with 1st corners, 1s dance 1/2 diagonal reel with 2nd corners
- 17-24** 1s dance 1/2 diagonal reel with 3rd corner (pstns), 1/2 diagonal reel with 4th corner (pstns)
- 25-32** 1s dance reel of 3 across (Lady with 2s, Man with 3s - LSh to 1st corner)
- 33-40** 2s+1s+3s circle 6H round & back

